

Ice Cream Freezer

Ice Cream Freezer

Economical Size and Design

*** Low Emissivity Glass**

No condensation on the glass-energy consumption limited

*** Economical & Convenient**

*** Holds -9°F~ 11°F (TGF-9F)**

*** Holds -9°F~ 1°F (TGF-13F)**



TGF-9F

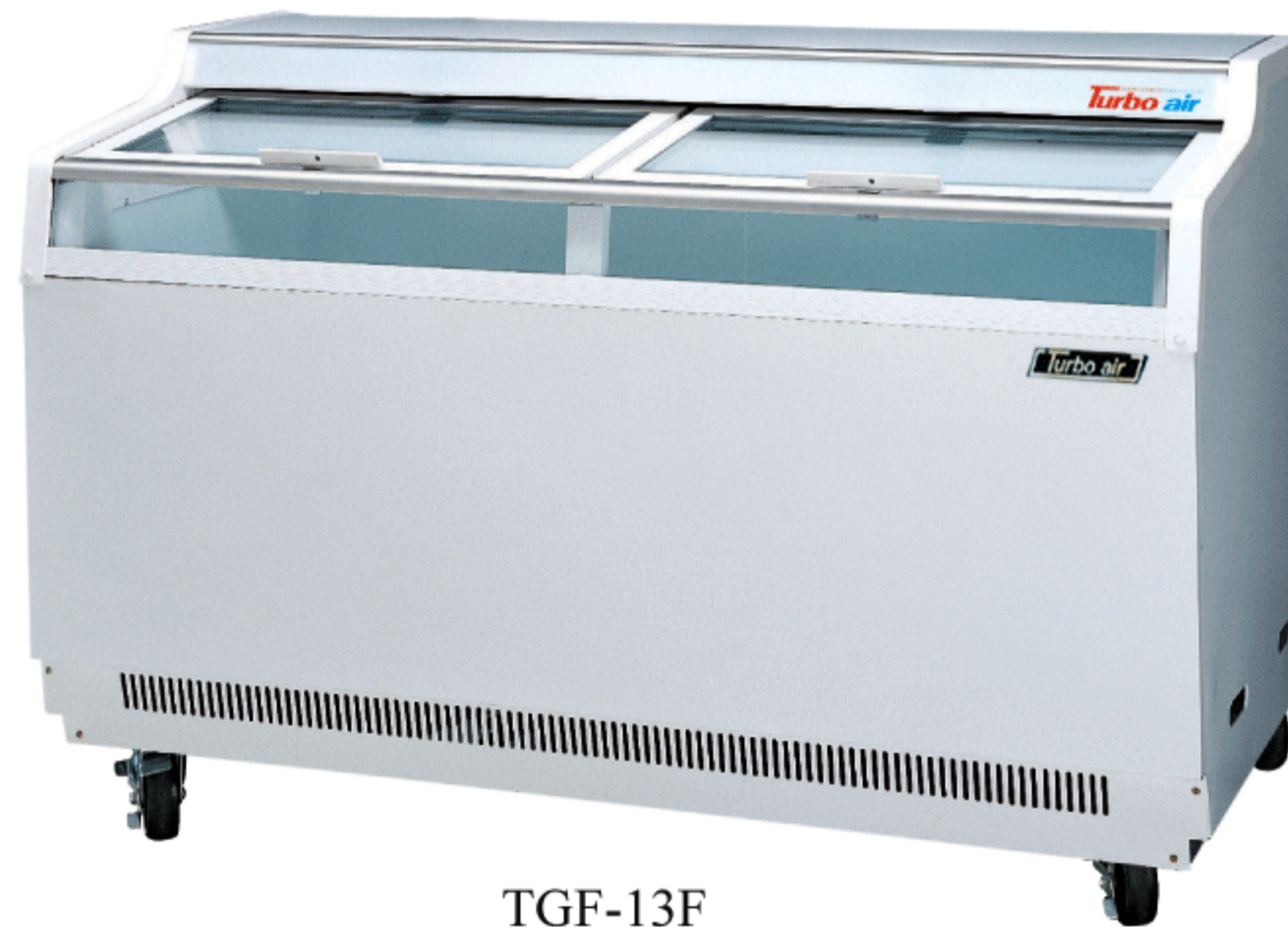

TGF-13F



ISO9001

Model	Slide Door	HP	AMPS	Weight	L D H	List Price
TGF-9F	1	1/4	6.0	185	44.3 x 27.4 x 39.4	2,321.00
TGF-13F	2	1/3	11.0	253	61.1 x 27.4 x 39.4	3,250.00

CABINET INTERIOR/EXTERIOR SPECIFICATIONS

MODEL	TGF-9F	TGF-13F
Exterior Dimensions	44.3x27.4x39.4	61.1x27.4x39.4
Power	115V/60Hz	115V/60Hz
Amp	6 A	11 A
Comp.	1/4HP	1/3HP
Slide Doors	1EA	2EA
Weight	185lbs	253lbs
Cubic Feet	8.5	13.3
Cord Length	9.85 feet	9.85feet
Plug-in	NEMA 5-15P	NEMA 5-15P

* Foamed With Polyurethane High -density Cell Insulation (CFC Free)

*Design and specifications can be changed without prior notice for product improvement.

(unit : inch)

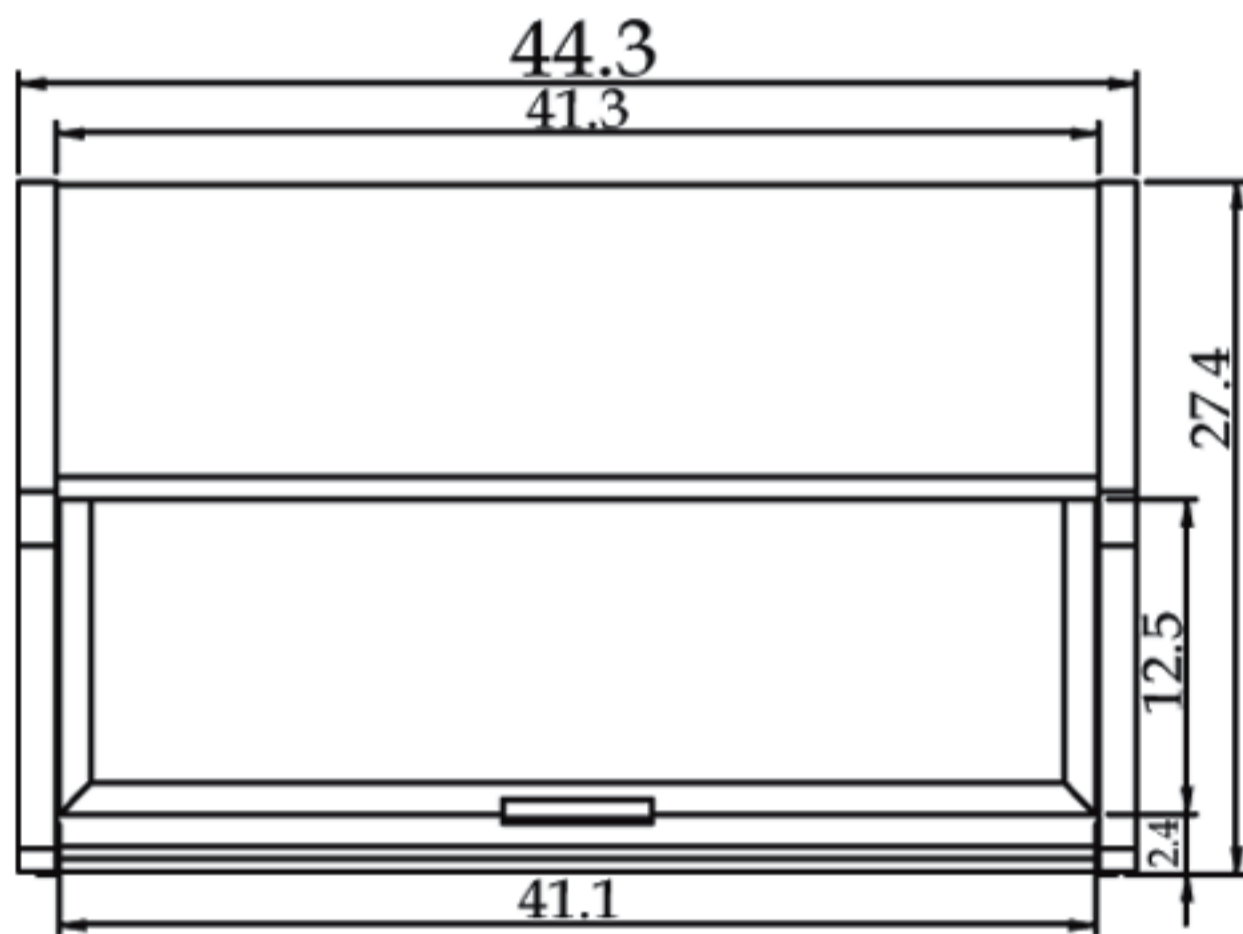

TGF-9F PLAN VIEW

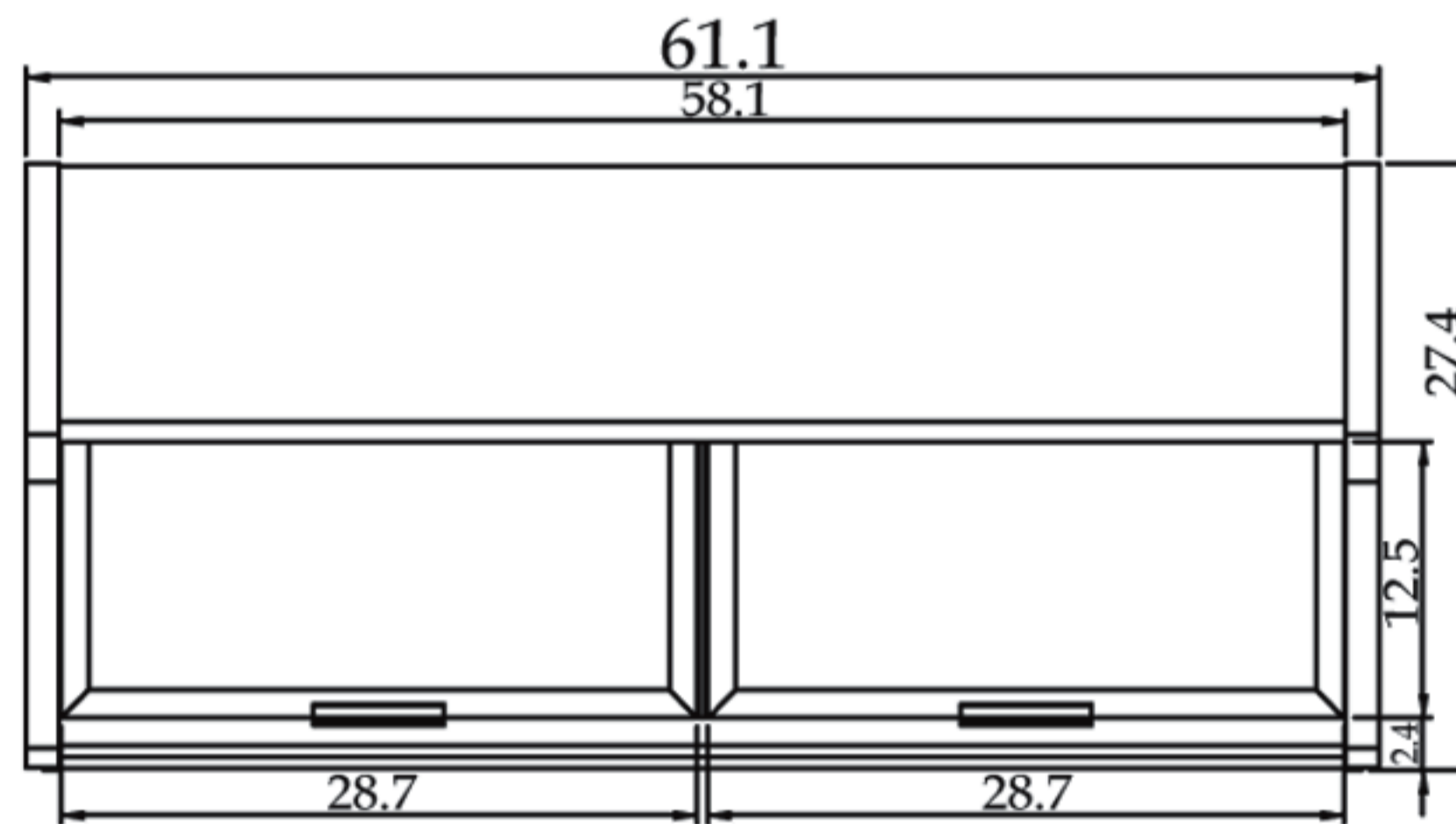

TGF-13F PLAN VIEW

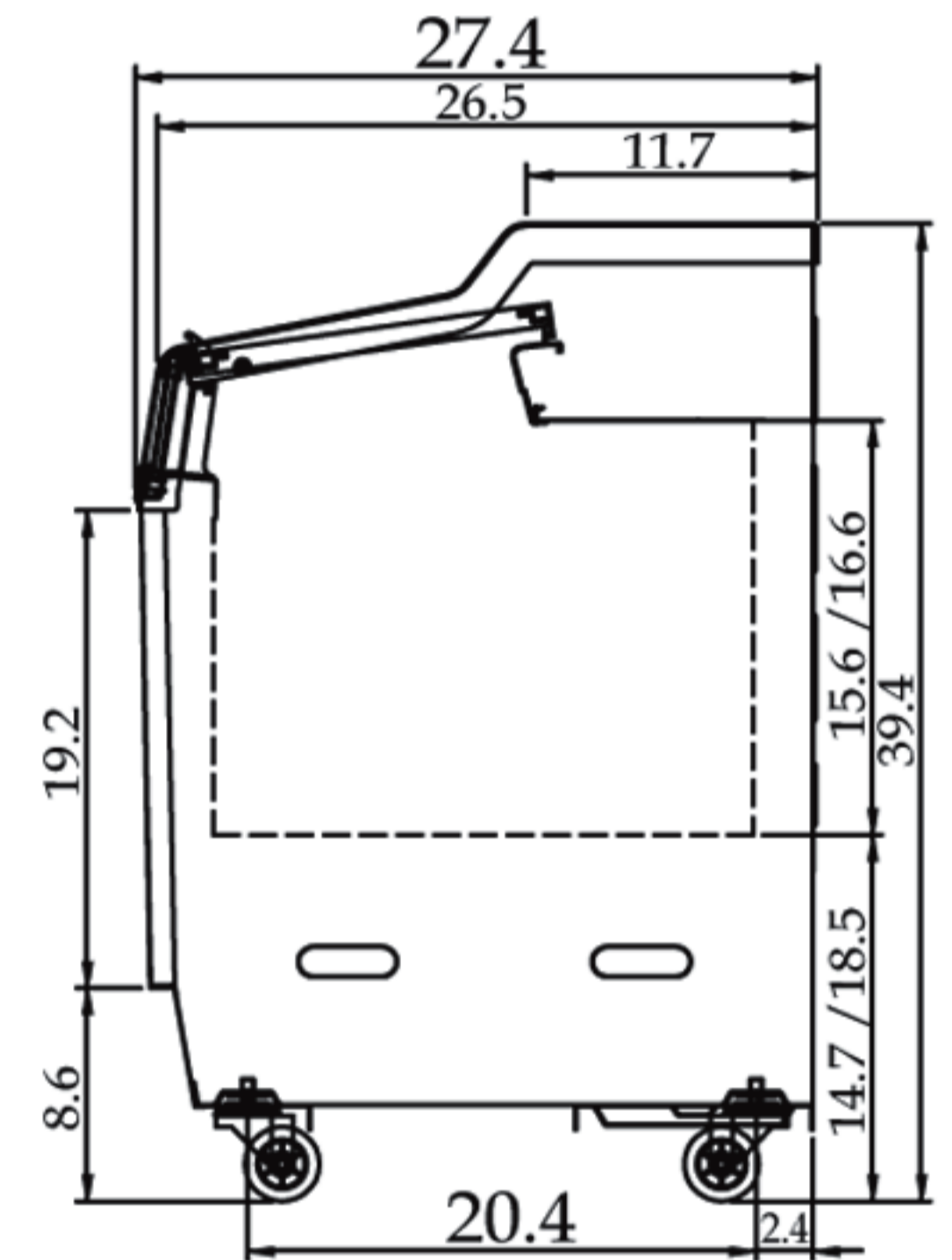

SIDE VIEW

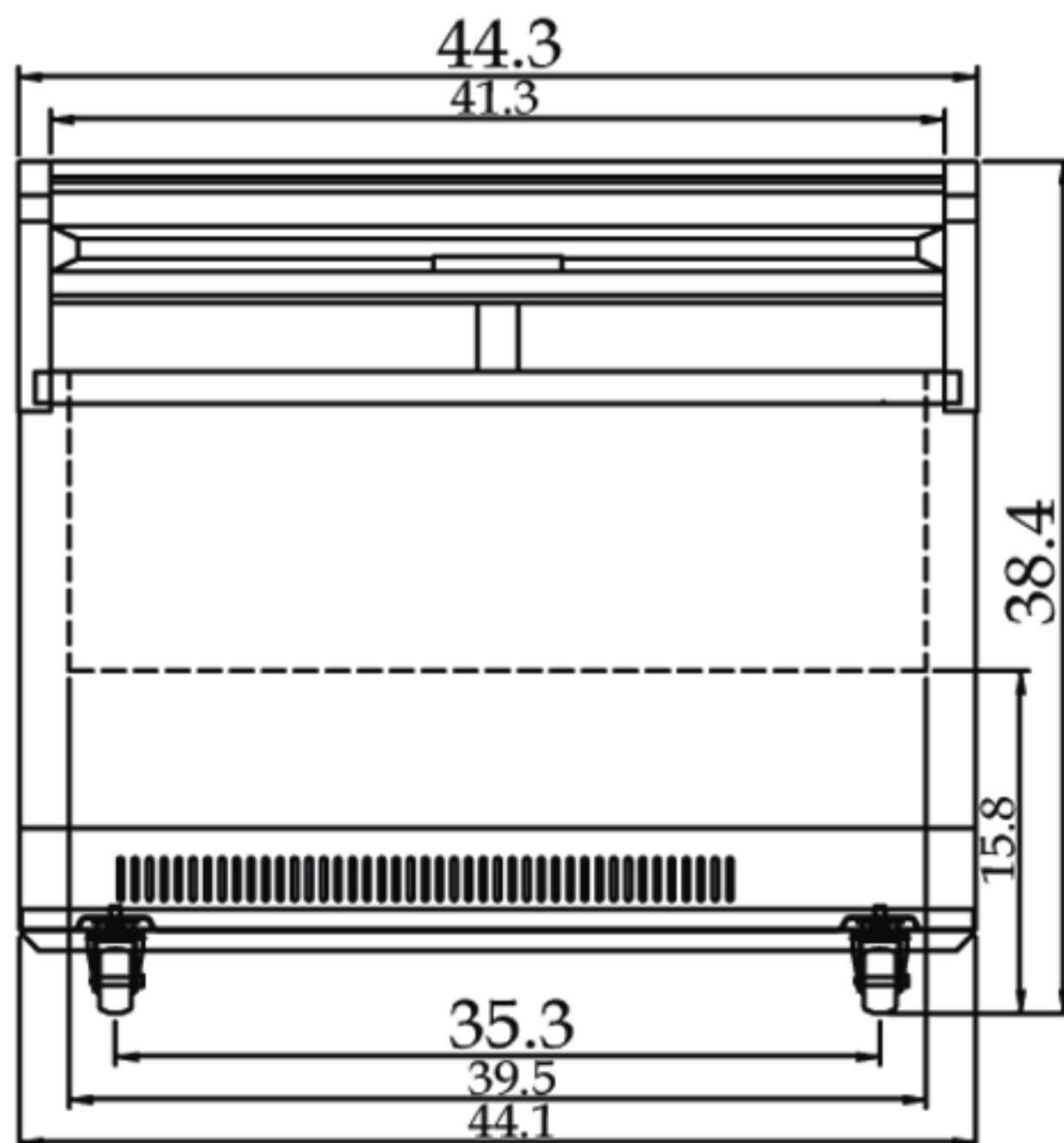

TGF-9F FRONT VIEW

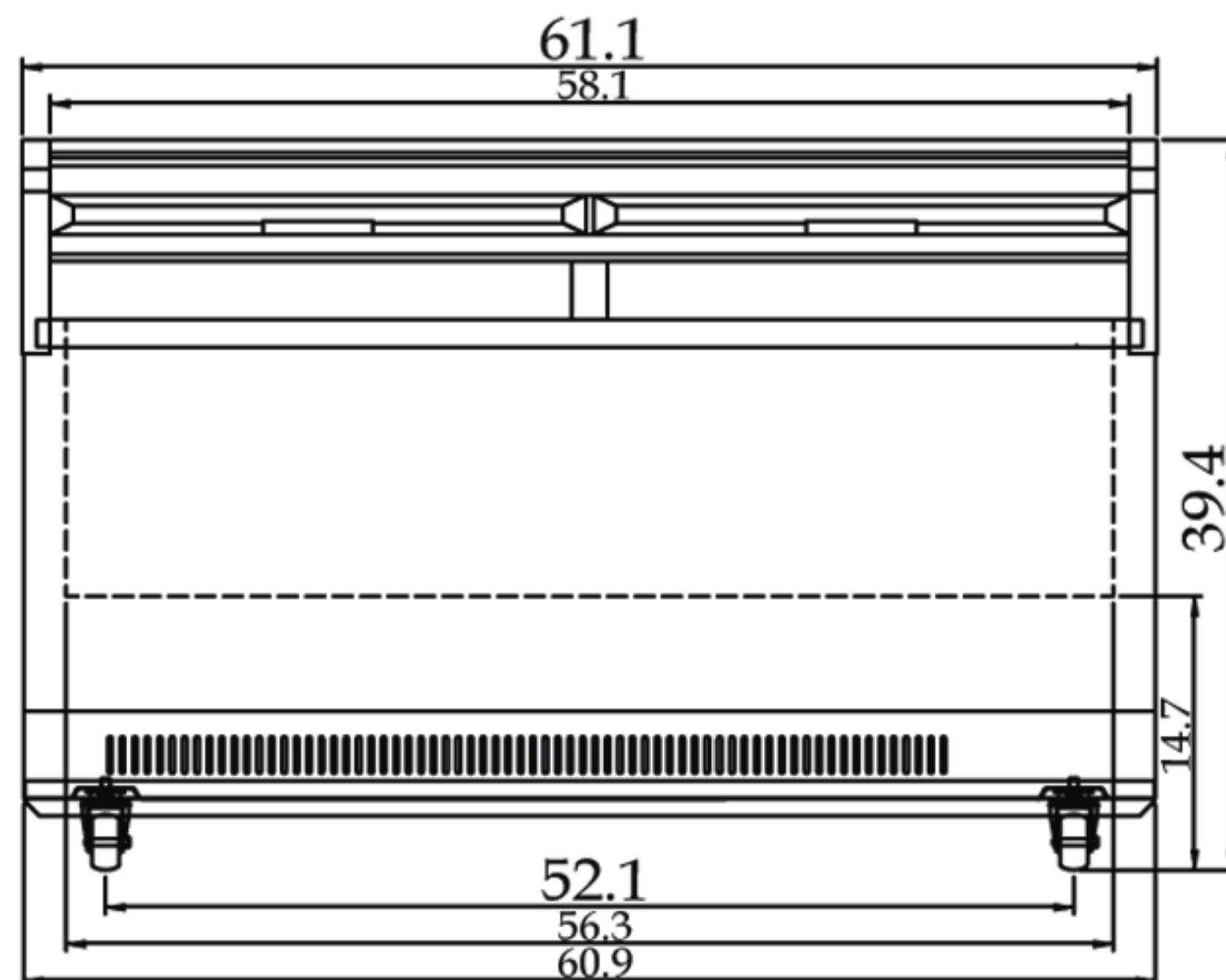

TGF-13F FRONT VIEW